

**BREAKDOWN BM-75**

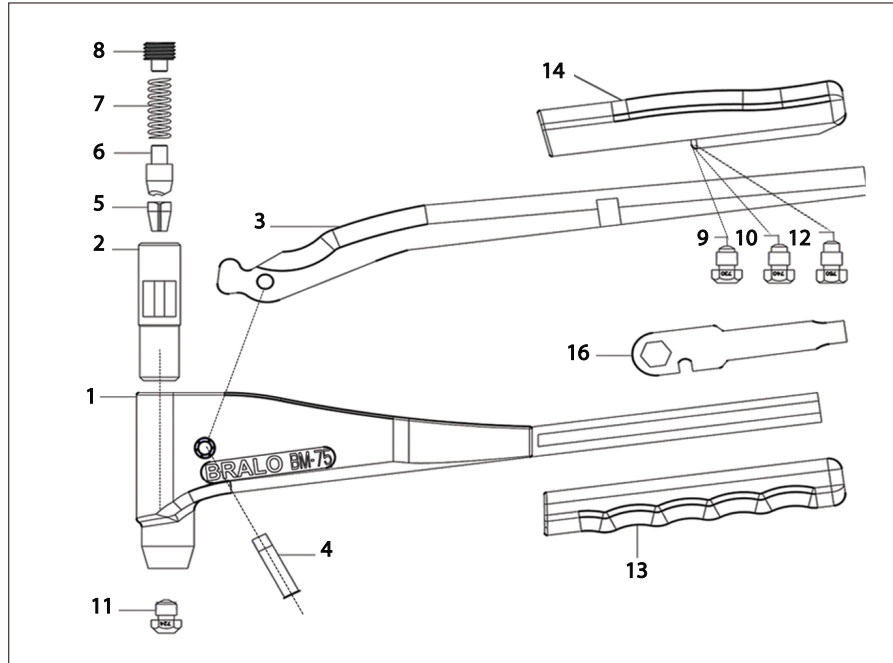

NOSEPIECE N°	ALUMINIUM	STEEL	STAINLESS STEEL	COPPER
724	d1 2,4		d1 2,4	
730	d1 3,0 - 3,2	d1 3,0 - 3,2		d1 3,0 - 3,2
740	d1 4,0	d1 4,0	d1 3,0-3,2-4,0	d1 4,0
750	d1 4,8 - 5,0			

N°	REFERENCE	DESCRIPTION
1	05BM0075001	Maincorp
2	05BM0075002	Jaw Case
3	05BM0075003	Steel Lever
4	05BM0075004	Screw pin
5	05BM0001001	Jaws (3 units)
6	05BM0075006	Jaw pusher
7	05BM0075007	Jaw pusher spring
8	05BM0075008	Jaw Case Cap
9	05BM0000724	Nosepiece n° 724 Rivet Ø 2,4
10	05BM0000730	Nosepiece n° 730 Rivet Ø 3,0-3,2
11	05BM0000740	Nosepiece n° 740 Rivet Ø 4,0
12	05BM0000750	Nosepiece n° 750 Rivet Ø 4,8-5,0
13	05BM0075013	Main handle
14	05BM0075014	Steel lever handle
16	05BM0075016	Key

